



# IMPROVING INFRASTRUCTURE SAFETY FOR POWERED TWO-WHEELERS

**A JOINT POSITION PAPER BY THE  
FEDERATION OF EUROPEAN MOTORCYCLISTS' ASSOCIATIONS  
AND THE  
EUROPEAN UNION ROAD FEDERATION**





## About the authors



Established in 1998, the European Union Road Federation (ERF) is non-profit association which defends the role of roads as a sine que non for Europe's socio-economic prosperity. With more than 60 members, it acts as a true platform for dialogue and research on issues related to safe mobility.

The Federation of European Motorcyclists' Associations (FEMA) represents European motorcyclists and aims to promote, protect and preserve motorcycling. Its mission is to promote riders' interests and defend riders' rights throughout Europe and globally.

## Executive Summary



Dolf Willigers  
FEMA General Secretary



Christophe Nicodème  
ERF Director General

Despite a recent stall in the reduction of fatalities, the EU has seen an impressive reduction of fatalities since 2001 of over 50%. At the same time, however, fatalities<sup>1</sup> of powered two-wheelers, while having decreased in absolute number, continue to represent an increasing percentage of total road fatalities, despite accounting for a relatively small share of total traffic. More specifically, motorcycle fatalities represent more 15% of total EU fatalities, while accounting only for 1,8% of the total traffic flow<sup>2</sup>.

Technological innovations in the field of infrastructure are naturally part of the answer to improving motorcycle safety from an infrastructure design point of view. Yet, in the opinion of ERF and FEMA, the most significant gains can be achieved by implementing solutions which are available today and are proven to be cost-effective. Simple things such as the installation of motorcycle protection systems in guardrails, maintaining the skid resistance of pavement markings and ensuring that roads surfaces are properly maintained can make an important contribution to the safety of riders and help achieve better progress towards reaching the EU's goal of reducing fatalities by 50% by 2020 in line with the objective set out in the Road Safety Action Program 2011-2020.

In this sense, this position paper will be structured along two main themes. As a first step, it will identify 'low-hanging fruits' that can be implemented today from an infrastructure perspective, identifying good practices already in place and make the case for their rapid implementation at EU and national level. As a second step, it will examine how infrastructure standards and design can be improved in the future in line with technological innovations taking place both from an infrastructure and vehicle perspective.

We wish you a pleasant reading.

1 In 2001, EU fatalities were 54900. By 2014, this number was down to 25900. [http://ec.europa.eu/transport/road\\_safety/specialist/statistics/index\\_en.htm](http://ec.europa.eu/transport/road_safety/specialist/statistics/index_en.htm)

2 Statistical Pocketbook 2016 – EU Transport in Figures <https://ec.europa.eu/transport/sites/transport/files/pocketbook2016.pdf>

## Taking advantage of 'low hanging fruits' to improve motorcycle safety



### 1.1 Making roadside forgiving for motorcyclists / using motorcycle protection systems

According to a CEDR report on forgiving roadsides<sup>1</sup>, 45% of fatal accidents are single vehicle primarily classified as run-off, i.e. where the vehicle leaves the road and enters the roadside.

To prevent such accidents, road safety practitioners have spent significant resources into developing forgiving roadsides. As a first step, this design philosophy states that 'roadside environment should not contain dangerous elements that will seriously injure or kill vehicle occupants that have unplanned trajectories off the carriageway. A fundamental component of this philosophy is the definition of an obstacle-free safety zone beside the carriageway<sup>2</sup>.

Given that, however, it is not always possible to remove obstacles, guardrails are often placed on roadsides to protect vehicles. As with most infrastructure solutions, they have been originally designed to protected cars and with this the needs of motorcyclists are overlooked. This means that traditional guardrails, instead of protecting riders, can represent in fact an obstacle in themselves.



Figure 1 : Traditional steel guardrail

As a response to the problem, solutions began emerging first at national level (France, Germany, and Spain) which eventually led to the approval of a voluntary testing protocol (TS 1317-8) for motorcycle protection systems (MPS) at European level in January 2012.

---

1 Forging roadsides design guide, [http://www.cedr.eu/download/Publications/2013/T10\\_Forgiving\\_roadsides.pdf](http://www.cedr.eu/download/Publications/2013/T10_Forgiving_roadsides.pdf)

2 Roadside Infrastructure for Safer European Roads [https://ec.europa.eu/transport/road\\_safety/sites/roadsafety/files/pdf/projects\\_sources/riser\\_guidelines\\_for\\_roadside\\_infrastructure\\_on\\_new\\_and\\_existing\\_roads.pdf](https://ec.europa.eu/transport/road_safety/sites/roadsafety/files/pdf/projects_sources/riser_guidelines_for_roadside_infrastructure_on_new_and_existing_roads.pdf)

Complementary to existing national testing protocols, the TS 1317-8 allows authorities to ask for crashworthy motorcycle protection systems to be installed on traditional guardrails.



Figure 2 : Steel guardrail with MPS system

Even though technical solutions exist nowadays, one of the main issues is the lack of real-live implementation. According to the RIDERSCAN project<sup>3</sup>, while the majority of European countries have some guidelines for powered two-wheelers in their national specification, these are only compulsory in two (Ireland, Norway). Moreover, six EU Member States (Bulgaria, Czech Republic, Greece, Latvia, Luxembourg and Poland) have no provisions for powered two-wheelers in their national guidelines. The end result is that many guardrails in curves remain unprotected and continue to represent a safety hazard for powered two-wheelers. According to the SMART RRS project, a fatal outcome is 2 to 5 times more likely for an impact with a crash barrier than for motorcycle accidents in general.

In this sense, FEMA and ERF urge both European and national policymakers to prioritise the introduction of motorcycle specific guidelines to ensure that all guardrails at hazardous locations are equipped with an MPS system. This can be achieved by:

- i) Ensuring that the revision of the Directive 2008/96 on Road Infrastructure Safety Management takes better into account the need for P2W
- ii) Introducing PTW-specific provisions into national guidelines that define a specific methodology of equipping traditional guardrails with motorcycle protection systems (MPS).

Given that the majority of accidents occur on secondary roads, priority should be given to guardrails installed in these parts of the network.

3 RIDERSCAN Deliverable 3, Infrastructure, [http://www.fema-online.eu/riderscan/IMG/pdf/deliverable3\\_infrastructure.pdf](http://www.fema-online.eu/riderscan/IMG/pdf/deliverable3_infrastructure.pdf)

**Good practice:** In the Netherlands in 2006, the then Minister of Transport decided to have steel barriers on all national roads in bends and other dangerous spots applied with motorcycle protection systems. Together the national road authority Rijkswaterstaat, the motorcyclist organizations MAG NL and KNMV developed a decision tree to establish the spots where the motorcycle protection systems should be installed. In the following years this was done, mostly together with regular maintenance.

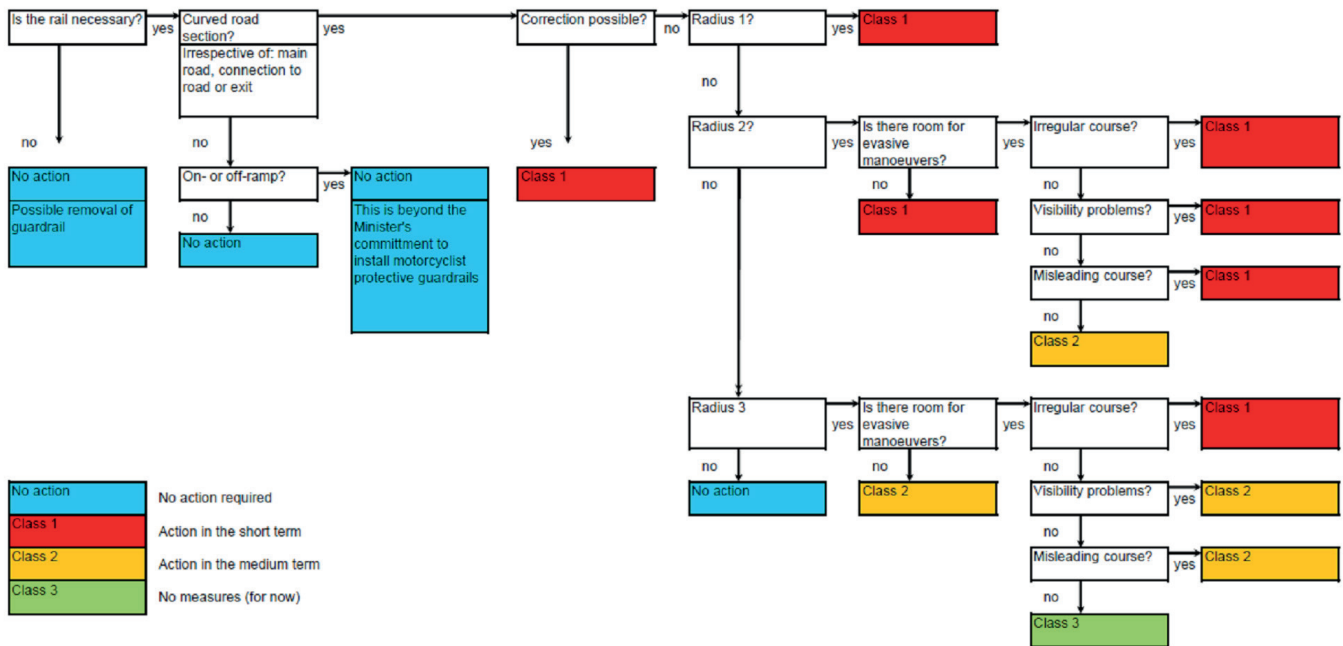

Figure 3: Decision tree MPS

## 1.2 Better maintenance of road surface and markings



Figure 4: Badly maintained road marking

**1.2.1 Skid resistance:** Skid resistance is defined as the frictional resistance at the interface between a vehicle tyre and the road surface. It plays an important part in the safety of road users, especially in bends and in zones with regular braking and accelerating

Due to lack of maintenance, road surfaces and pavement markings gradually lose their skid resistance and this represents a particular hazard for motorcycles, especially during wet conditions. According to a study carried out by the Belgian Road Safety Institute, approx. 30% of all single vehicle PTW

accidents occur on local roads representing 38% of fatal accidents. <sup>4</sup>

With respect to pavements, there currently exists no standardised method for measuring skid resistance given that EU countries use different systems to measure it on the road and also have different approaches to the required level of skid resistance as an indicator for safety. Nevertheless, all existing dynamic measurement systems are currently grouped in the TS 13036-2, which allow authorities to survey the condition of the road at regular intervals and ensure that skid resistance levels do not drop below safety critical thresholds.



Figure 5: Sideway Force measure truck

Skid resistance for road markings is one of the main elements assessed during the certification phase of such products in accordance to EN 1436. In other words, all road markings initially installed on road surfaces have demonstrated adequate skid resistance levels in line with the requirements of Member States. The problem is that authorities fail to renew markings at appropriate intervals which represent a safety hazard both in terms of the lack of visual guidance on the road and a particular hazard for riders. Authorities can either undertake measurements (dynamic or static) to assess the skid resistance levels or simply replace markings in line with their functional predicted life-time.

4 Motorcycle Accident Causation, [http://www.vias.be/publications/MOTAC%20%E2%80%93%20Motorcycle%20accident%20causation%20\(1\)/MOTAC%20%E2%80%93%20Motorcycle%20accident%20causation%20\(EN\).pdf](http://www.vias.be/publications/MOTAC%20%E2%80%93%20Motorcycle%20accident%20causation%20(1)/MOTAC%20%E2%80%93%20Motorcycle%20accident%20causation%20(EN).pdf)



### 1.2.2 Smoothness of road surface

In addition to ensuring that road and pavement markings have sufficient overall levels of skid resistance, there are even more simple steps that road authorities can take to ensure the roads remain safe for riders and overall traffic.

**Eliminating potholes and fissures:** due to cutbacks in maintenance especially at regional and local level, potholes and fissures are becoming unfortunately a frequent phenomenon for daily users. While more of nuisance for car drivers, a pothole can actually represent a serious threat for a rider who risks losing control of his motorcycle and getting involved in a lethal accident. Similarly, road fissures (cracks) can cause unevenness in the surface which may cause riders to lose control.



Picture 6: Potholes/fissures

### Debris, pollution and fallen loads/spillage on the road surface

Debris on road surfaces form a greater risk for powered two-wheelers than for other vehicles. Motorcycles may easily lose grip and fall. Many countries already have regulations that demand both the polluters and the road authorities to keep the road surfaces clean and safe for users. Authorities should enforce this. Picture 7 shows dried clay, that will be very slippery when it gets wet. This kind of debris is often caused by farmers or contractors that work off-road and bring this on with the tires of off-road machines.



Figure 7: Debris

Another form of debris is grit from wear or maintenance. After roadworks the road should always be cleaned and after some time inspected and cleaned again.

### Design of urban cross roads

Accidents happen on urban cross roads for various reasons. Drivers do not give right of way because the situation is not clear, they didn't see or recognise the other vehicle (often a powered two wheeler) or because they underestimate the speed of the other vehicle. Road authorities can better the situation by removing all objects that block the view. In case of parked cars a solution could consist in redesigning the road, removing parking spaces, introducing parking prohibition, or removing or replacing fixed objects like trees, advertisement poles, traffic signs, light poles. Other options are regulating the right of way in a manner that conflicts of oncoming and deflecting traffic are avoided, making the right of way indicated more clearly, redesign the cross roads, for example in a roundabout or use traffic lights.



Figure 8 : Obstacles blocking the view at a cross road

### Manhole covers

Manholes and manhole covers provide several dangers for motorcyclists: the iron manhole covers often are slippery, especially when wet. A front wheel of a motorcycle can slip away on this, causing the rider to lose balance and fall. Also the manhole cover need to be on the same level as the pavement.

In practice the manhole cover often lies on a lower level which also can cause loss of balance for a motorcyclists. For this reason motorcyclists try to avoid manhole covers. To enhance safety manhole covers should not lie in the regular riding line of motorcycles, the upper site of the manhole cover should be on the same level as the pavement and the material of the manhole cover should not be slippery (ideal is the same skid resistance as the pavement) or covered with a non-slippery coating.



Figure 9 : Dangerous manhole cover in Sweden



Figure 10 : Manhole cover before anti-skid treatment



Figure 11 : Manhole cover after anti-skid treatment

## Future challenges for road infrastructure



### Recommendations for the retro-fitting of existing guard

The development and approval of the TS 1317-8 in 2012 means that road authorities can require such systems when procuring new guardrails on their national road network. At the same time, however, most guardrails existing on the road have been placed before the TS 1317-8 existed and such needed to be retro-fitted with an MPS.

In France, a new national specification imposes the installation of MPS on all new road infrastructure in the following cases:

- On motorways and dual-carriageway roads, in curves with a radius inferior to 400 m, on the external side;
- On other roads, in curves with a radius inferior to 250 meters, on the external side;
- In case of a grade-separated intersection, independently on the type of road, radius and direction of the curve, on the external side.

This specification could be a reference for the retro-fitting of existing guardrails.

### Updating of the TS 1317-8 for Motorcycle protection systems

While the development of testing protocol for motorcycle protection systems is definitely a step forward, the standard could benefit from an update to take into account different impact scenarios.

The current testing protocol assumes the loss of the control by the rider from the motorcycle and the rider subsequently sliding towards a guardrail as pictured below.

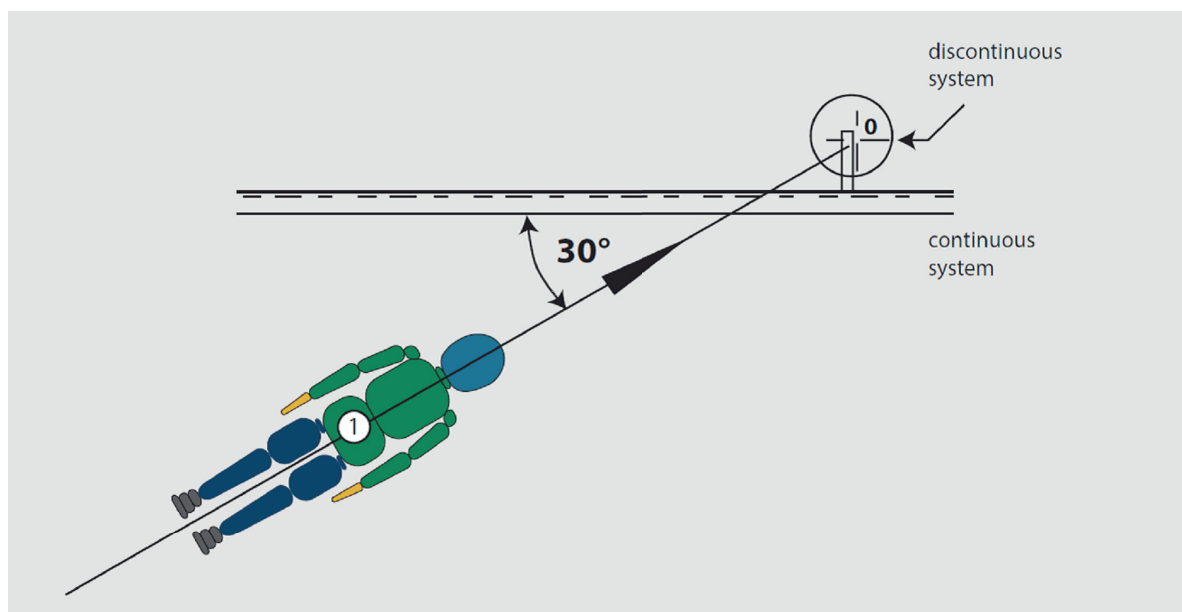

Figure 12 : Impact scenario according to TS 1317-8

Nevertheless, and according the smart RRS project, in 50% of the PTW accidents against a road restraint system, the rider is still in an upright riding position when the impact occurs, with the associated risks of being thrown on or over the barrier. Currently, this scenario is not considered in existing standards and is not currently included in the CEN/TS 1317-8 although this document does recognise the need to add this complementary crash configuration in the future. This issue was also highlighted in the recent literature study entitled 'Definition of a safe barrier for a motorcyclist' released by the Swedish Motorcycle Association, the Swedish Safety Barrier Association and VTI.

When a rider, as a result of an impact with a safety barrier, is actually sliding on the top the barrier, he risks coming into contact with the upper parts of the posts of the guardrail which can provoke physical harm found in the back of standard guardrails.



Figure 13 : Guardrail post as seen from the back of the barrier.

As a result, the paper highlighted the need for developing guardrails with contain also protection on the top of the barrier to prevent such impacts.

Limited systems exist on the market today given that authorities do not specify such requirements in their national implementation guidelines. Appropriate modifications to traditional guardrails fitted with MPS can be made by the industry and authorities should actually introduce such specifications in their tenders.

At the same time, the literature review highlighted the need to develop a guardrail system which, apart from have a smooth top, can have an overrun protection fitted. Such possibilities should be explored within CEN TC 226 when examining the revision of the TS 1317-8.

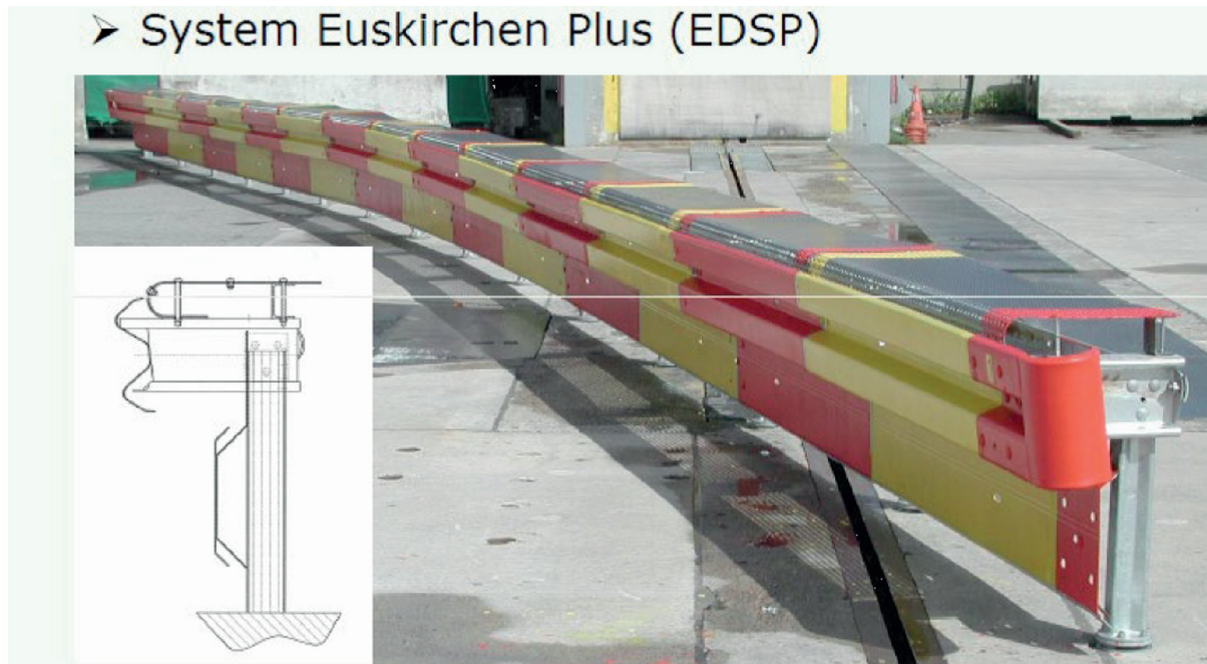

Figure 14 : Guardrail with smooth top

#### Update of EN 124:2015

While containing reference to skid resistance requirements, the current thresholds for skid resistance for manhole covers are too low to provide adequate protection for P2W. As such, it is recommended that any future revision of the standard does seek to address this issue through the enhancement of skid resistance requirements.



**Square de Meeûs 18  
1050 Brussels  
Belgium**

**[www.fema-online.eu](http://www.fema-online.eu)**



**Place Stéphanie 6/B  
B-1050 Brussels  
Belgium**

**[www.erf.be](http://www.erf.be)**

